

The background of the slide is a blurred image of a green car moving from left to right. The car's front wheel, side mirror, and part of the hood are visible on the left side. The background is a mix of green and white streaks, suggesting speed. At the bottom of the slide, there is a decorative pattern of white dots of varying sizes, arranged in a way that suggests a sound wave or a digital signal.

autoneum

January 15 & 16, 2026 . Bernhard Wiehl, CFO

# Octavian Seminar in Davos

Autoneum. Mastering sound and heat.

# Key Figures Overview

CHF million	HY1 2024	HY1 2025	Change
Revenue	1212.3	<b>1171.6</b>	-40.8
EBITDA	128.1	<b>125.8</b>	-2.4
<i>in % of revenue</i>	<i>10.6%</i>	<i><b>10.7%</b></i>	
EBIT	65.8	<b>61.9</b>	-3.9
<i>in % of revenue</i>	<i>5.4%</i>	<i><b>5.3%</b></i>	
Net result	36.1	<b>40.7</b>	4.6
Free cash flow*	39.1	<b>48.4*</b>	9.3
Basic earnings per share (EPS) in CHF	4.86	<b>5.16</b>	0.29

\* HY1 2025 free cash flow excl. one-off M&A-related net cash outflow

## Solid Performance in a Challenging Market



Resilient EBIT margin, only slightly below prior-year period



Free cash flow on track for 2025 target



Net result significantly improved



Jiangsu Huanyu acquisition contributing positively to Group performance



Successful turnaround in North America confirmed



Expansion of sustainable product portfolio

# Strong Regional Performance Across All Markets

## Driving Forward With Sustained Strength and Confidence



**Europe:** Fairly stable EBIT margin despite market decline



**Asia:** Revenue boost from acquisitions, EBIT up



**North America:** Turnaround confirmed, EBIT margin at 5.1%



**SAMEA:** Best-in-class EBIT margin of 14.7%

# Guidance 2025, Issued in March 2025, Still Valid



## Revenue

According to the February market forecast\*, automobile production will show no growth in 2025. Consequently, Autoneum expects revenue of CHF 2.3 to 2.5 billion for the 2025 financial year, which includes the acquisition of Jiangsu Huanyu Group, effective February 28, 2025.

\*Source: S&P Global Mobility Light Vehicle Production Market Forecast of February 18, 2025.



## Profitability and free cash flow

Based on the expected revenue, for the 2025 financial year Autoneum anticipates an EBIT margin of 5% to 6% and a free cash flow of around CHF 100 million (excluding the one-off net cash outflow for M&A transactions).

## Mixed Picture

- 89.6 m units Actuals 2024 (-1.0% vs 2023)
- 92.4 m units Forecasted 2025 (3.2% vs 2024)
- 91.9 m units Forecasted 2026 (-0.5% vs 2025)

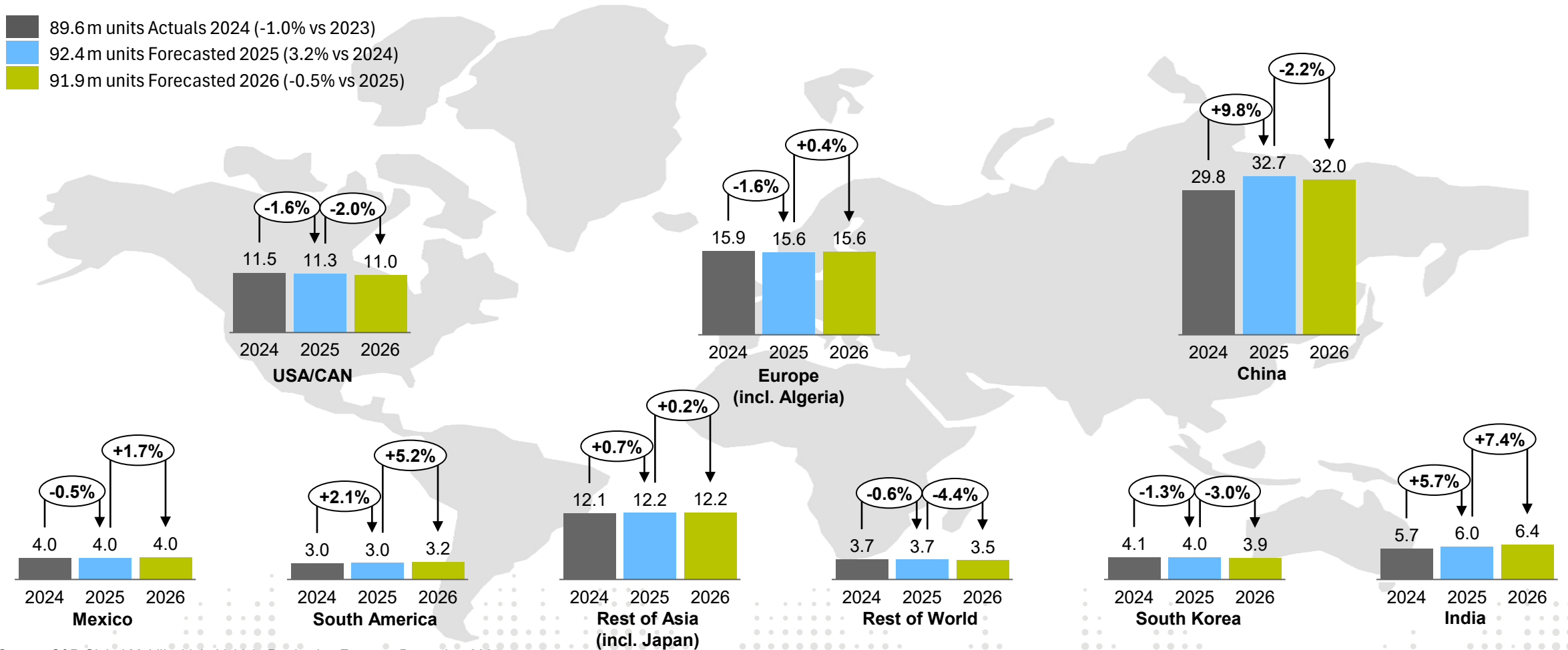

Source: S&P Global Mobility Light Vehicle Production Forecast December 2025

## Medium-Term Targets

### Financial targets



**Revenue**  
CHF 3 billion\*



**EBIT margin**  
6% to 8%  
over the cycle



**Free cash flow**  
>5% of revenue



**Net debt to EBITDA**  
(incl. IFRS 16)  
<1.5x

### ESG targets

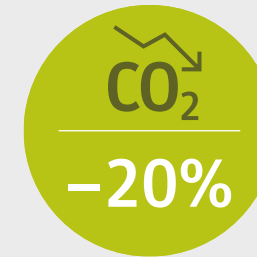

**CO<sub>2</sub> emissions**  
**Scope 1 and 2**  
Reduce by 20%\*\*



**Non-hazardous waste**  
Reduce by 40%\*\*



*Pro memoria:* Unchanged policy of dividend payout of at least 30% of net profit attributable to shareholders of Autoneum Holding Ltd

\*at 2024 foreign currency exchange rates

\*\*baseline 2019, to be reached by 2027

# About Autoneum

---



## Key Financials

**2338.7**

CHF million  
**Revenue**

**5.3%**

**EBIT margin**

**70.0**

CHF million  
**Net result**

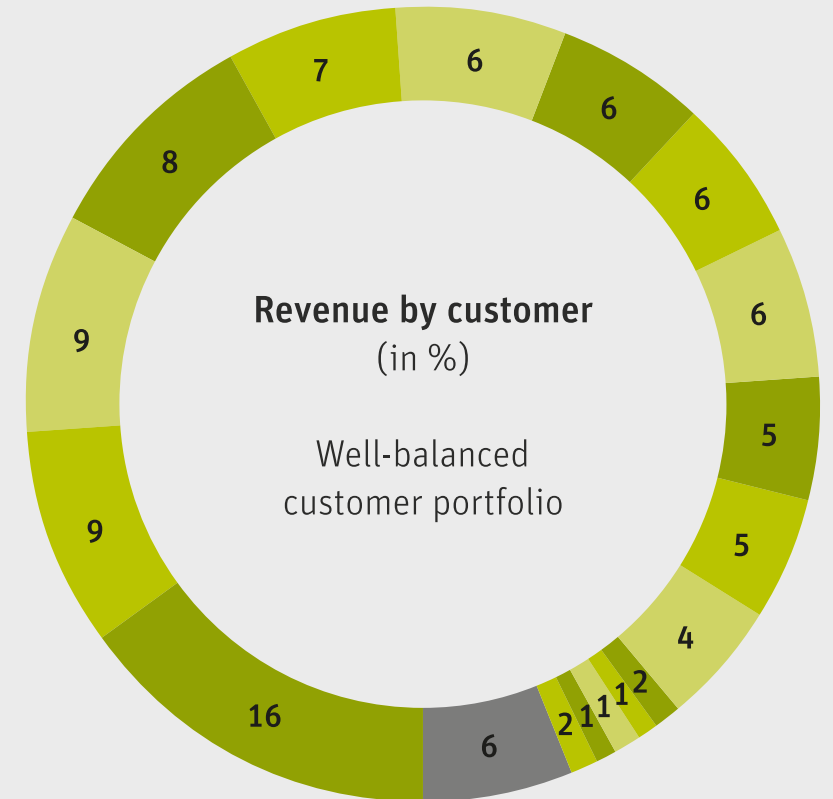
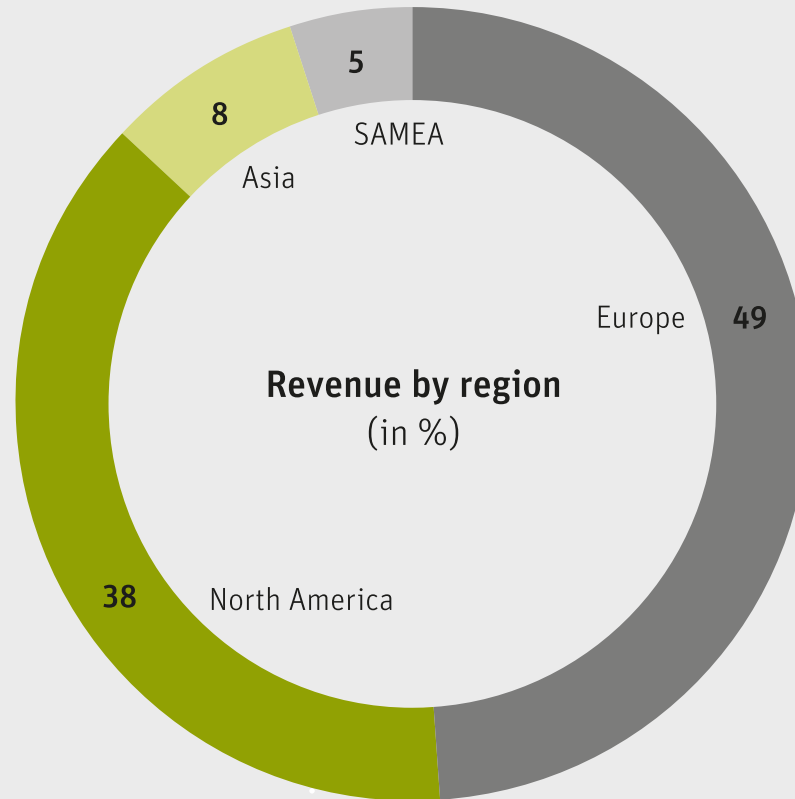

# History

## 120 Years of Expertise

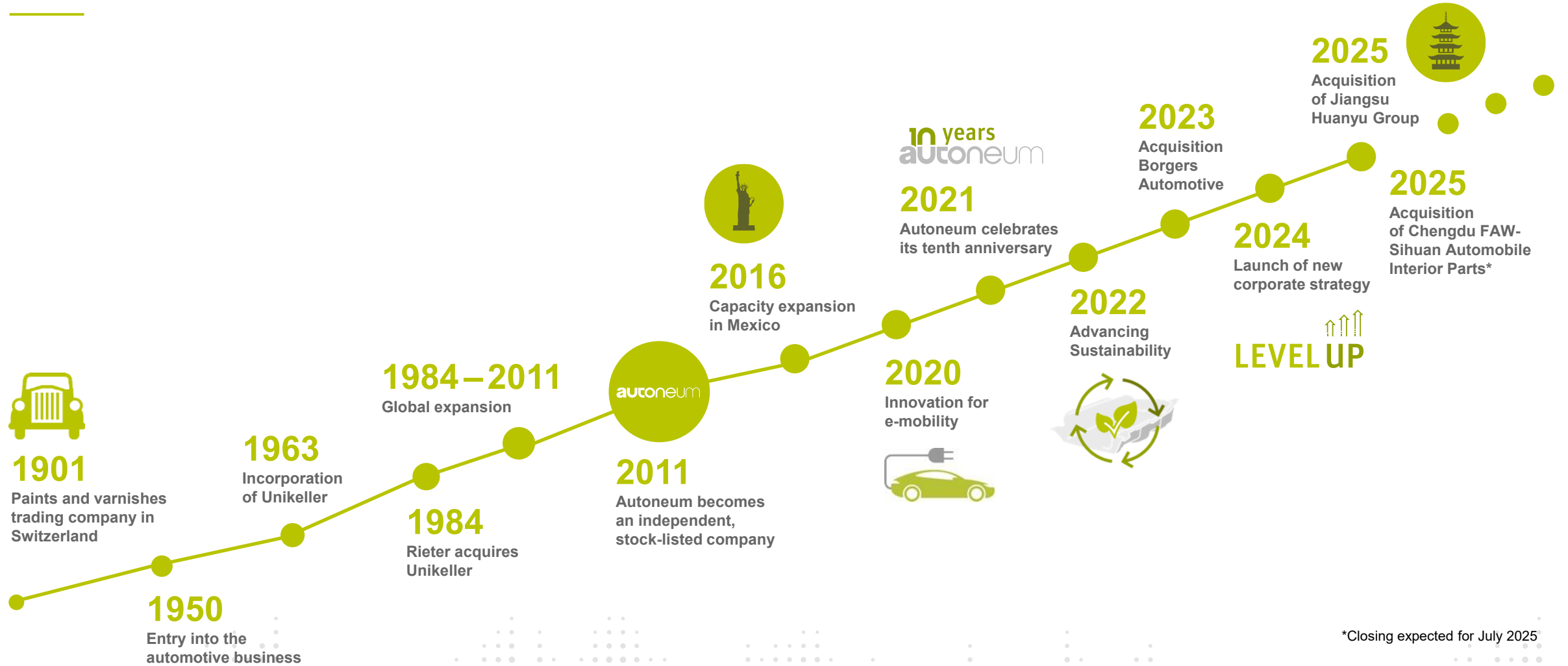

\*Closing expected for July 2025

# Our Purpose, Vision, Mission & Values

### Purpose:

We care to make mobility comfortable and sustainable.

### Vision:

Be the global leader for innovative and sustainable solutions bringing comfort to every vehicle.

### Mission:

We expand our global market and technology leadership mastering vehicle acoustics, thermal management and shielding technologies.

We act as one team to turn opportunities into realities - for all our stakeholders and the world we live in.

### Values:



ACCOUNTABILITY



CURIOSITY



COLLABORATION



COURAGE

# Global Market Leadership

## Key Differentiators That Make Autoneum Stand Out



Solid customer partnerships



Innovation pipeline for future-fit products

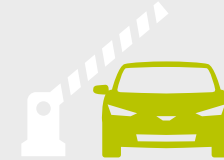

High entry barriers



Vertical integration and recycling expertise



Global presence with a strong brand



High level of ESG standards implemented



Scientific leadership and strong protection by intellectual property rights



Financial stability in a consolidating market

Level Up

# Strategic Priorities



Shape a future-fit product portfolio



Innovate to create customer value



Accelerate global growth



Foster a people centric culture



Be the sustainability benchmark



Boost cost-competitiveness

# Strategic Progress in Asia

## Strengthening Customer Portfolio & Regional Presence



Growth with Chinese OEMs accelerating

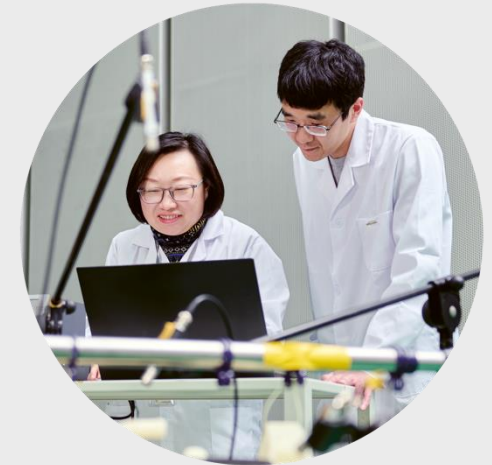

Acquisitions in China expanding customer base

R&T center in China supports local innovation

# Global Presence

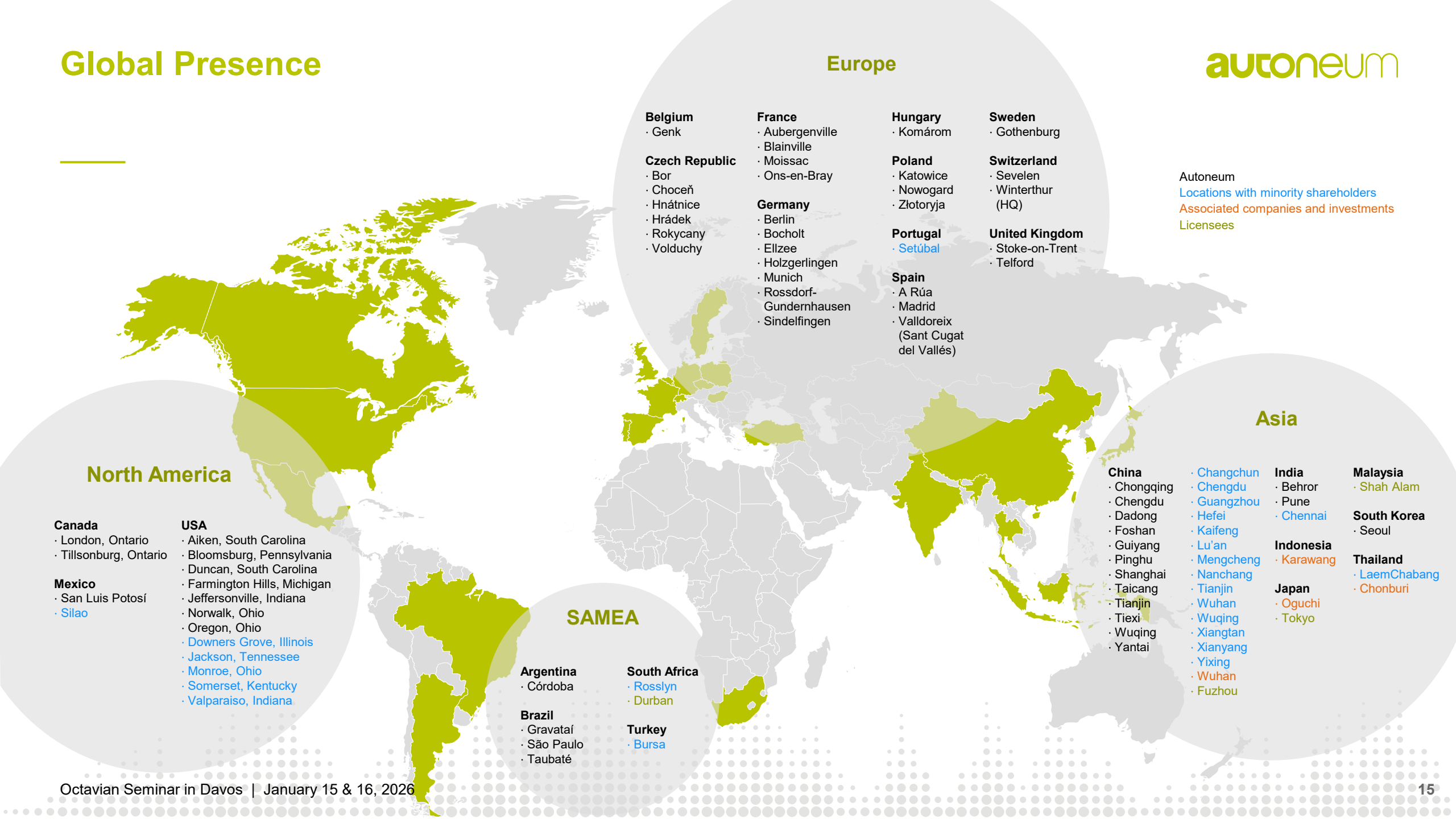

## Europe

- Belgium**
  - Genk
- Czech Republic**
  - Bor
  - Choceň
  - Hrátnice
  - Hrádek
  - Rokycany
  - Volduchy
- France**
  - Aubergenville
  - Blainville
  - Moissac
  - Ons-en-Bray
- Germany**
  - Berlin
  - Bocholt
  - Ellzee
  - Holzgerlingen
  - Munich
  - Rossdorf-Gundernhausen
  - Sindelfingen
- Hungary**
  - Komárom
- Poland**
  - Katowice
  - Nowogard
  - Złotoryja
- Portugal**
  - **Setúbal**
- Spain**
  - A Rúa
  - Madrid
  - Valldoreix (Sant Cugat del Vallés)
- Sweden**
  - Gothenburg
- Switzerland**
  - Sevelen
  - Winterthur (HQ)
- United Kingdom**
  - Stoke-on-Trent
  - Telford

Autoneum  
 Locations with minority shareholders  
 Associated companies and investments  
 Licensees

## North America

- Canada**
  - London, Ontario
  - Tillsonburg, Ontario
- Mexico**
  - San Luis Potosí
  - **Silao**
- USA**
  - Aiken, South Carolina
  - Bloomsburg, Pennsylvania
  - Duncan, South Carolina
  - Farmington Hills, Michigan
  - Jeffersonville, Indiana
  - Norwalk, Ohio
  - Oregon, Ohio
  - **Downers Grove, Illinois**
  - **Jackson, Tennessee**
  - **Monroe, Ohio**
  - **Somerset, Kentucky**
  - **Valparaiso, Indiana**

## SAMEA

- Argentina**
  - Córdoba
- Brazil**
  - Gravataí
  - São Paulo
  - Taubaté
- South Africa**
  - **Rossllyn**
  - Durban
- Turkey**
  - **Bursa**

## Asia

- China**
  - Chongqing
  - Chengdu
  - Dadong
  - Foshan
  - Guiyang
  - Pinghu
  - Shanghai
  - Taicang
  - Tianjin
  - Tiexi
  - Wuqing
  - Yantai
- India**
  - Behror
  - Pune
  - **Chennai**
- Indonesia**
  - **Karawang**
- Japan**
  - **Oguchi**
  - Tokyo
- Malaysia**
  - **Shah Alam**
- South Korea**
  - Seoul
- Thailand**
  - **LaemChabang**
  - **Chonburi**
- China (continued)**
  - **Changchun**
  - **Chengdu**
  - **Guangzhou**
  - **Hefei**
  - **Kaifeng**
  - **Lu'an**
  - **Mengcheng**
  - **Nanchang**
  - **Tianjin**
  - **Wuhan**
  - **Wuqing**
  - **Xiangtan**
  - **Xianyang**
  - **Yixing**
  - **Wuhan**
  - **Fuzhou**

# Most Car Manufacturers Worldwide

Light vehicles



Commercial vehicles





## Be the Sustainability Benchmark

# Clear Strategic Focus Leveraging Autoneum's Strengths

### Main focus areas

### Autoneum's strengths



Climate change mitigation and adaptation

- Product portfolio largely fit for **all types of powertrains**
- New **opportunities for electric vehicles**
- Long history of **lightweight low carbon footprint technologies**
- Committed organization on **energy saving**

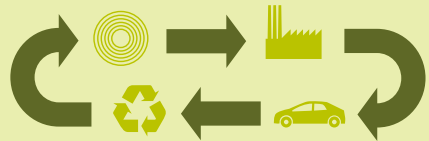

Towards a circular economy

- **Vertical integration** and **recycling expertise**
- Development lead on **mono-material solutions**
- Sustainability embedded in **innovation process**
- Partnership with **leading vehicle manufacturers** on sustainability



Supply chain engagement

- **“A-” score in CDP** supplier engagement questionnaire
- Highest standard required in our new **supplier code of conduct**



# A Product Portfolio Fit for the Circular Economy

## From Multi- to Mono-Material Carpet Systems

### Complex bill of materials of traditional carpet system

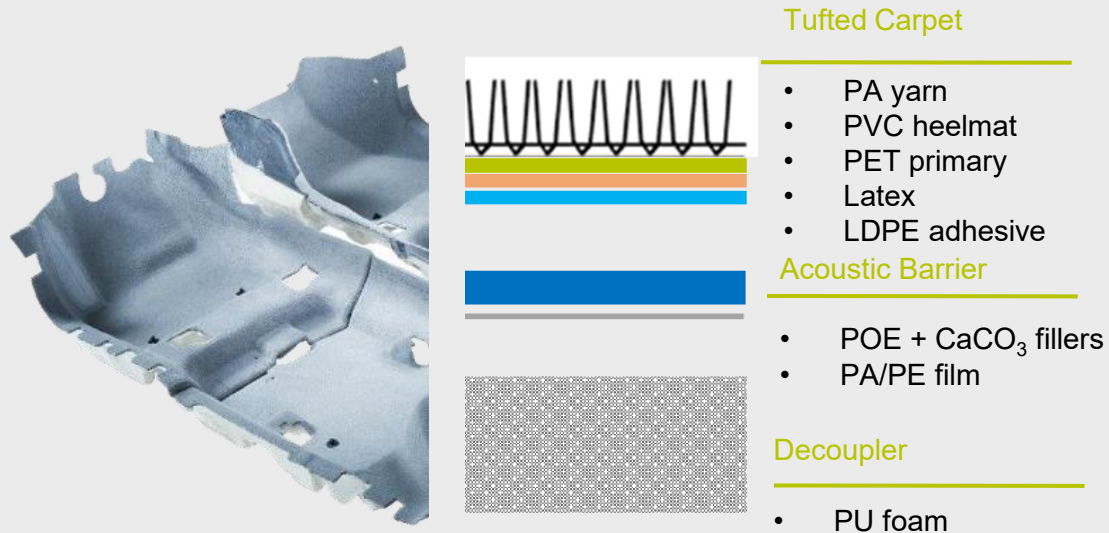

- ✓ Recycled material content < 10%
- ✓ Trim waste only landfilled
- ✓ No end-of-life concept

### Simplified bill of materials of monomaterial carpet systems

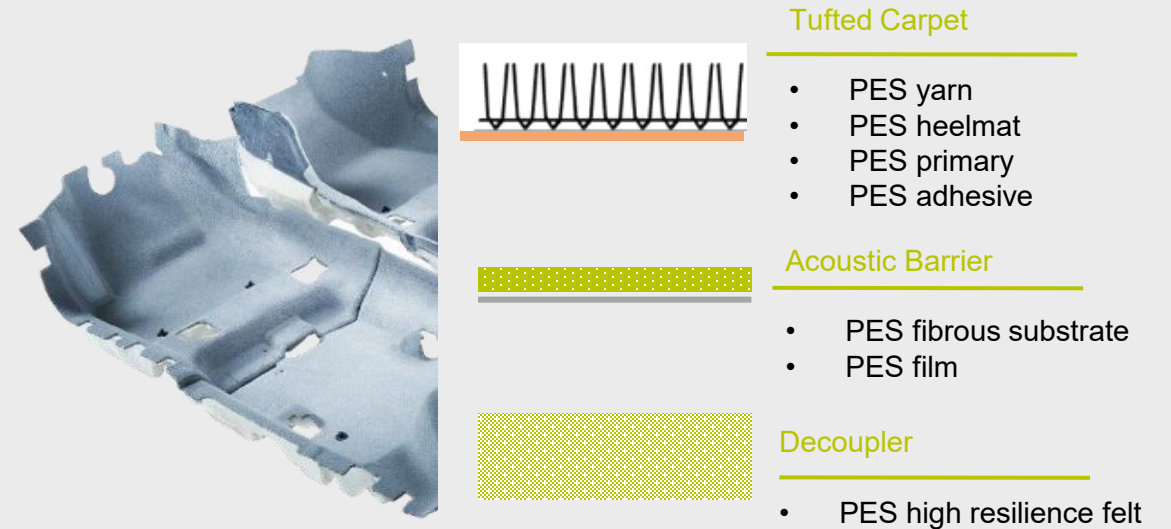

- ✓ Recycled material content > 50%
- ✓ Trim waste 100% recyclable
- ✓ ELV<sup>1</sup>: 100% recyclable carpet systems

<sup>1</sup>ELV: End of Life Vehicle

## Our Products for Light Vehicles of All Drive Types

### Exterior

#### Engine bay

- Frunk
- Engine\* and e-motor encapsulations
- Outer dashes
- Outer trunk floor insulators
- Hoodliners
- Engine top covers\*

#### Underbody

- Underbody shields
- Under battery shields
- Wheelhouse outer liners
- Outer tunnel insulators\*
- Heatshields\*
- Battery electromagnetic shields
- Outer floor insulators

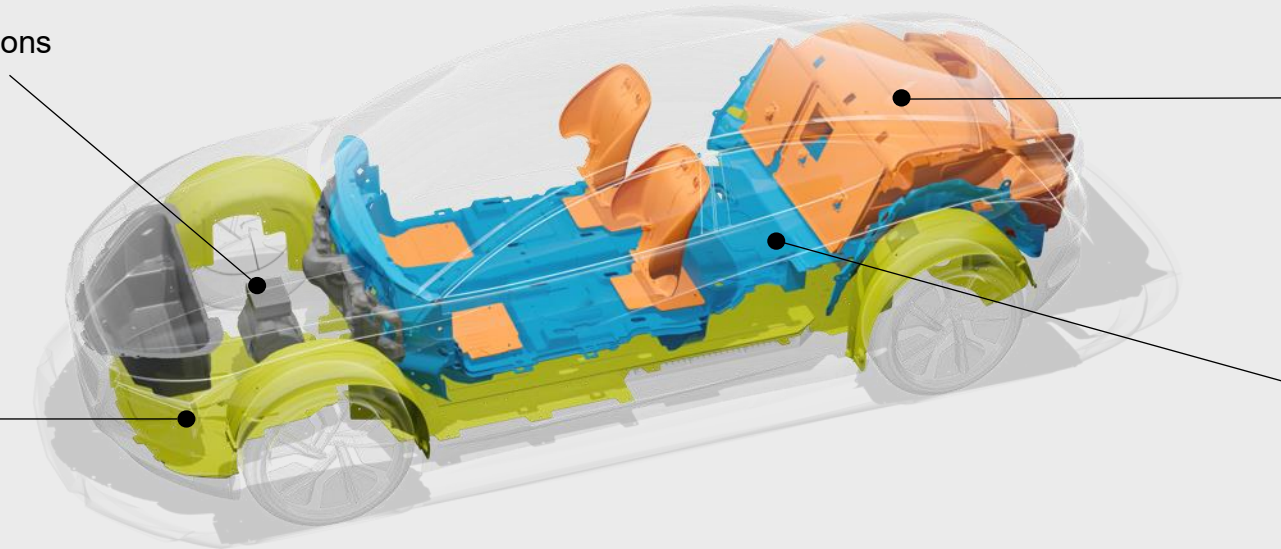

### Interior

#### Interior trim

- Trunk side trim
- Trunk load floors
- Trunk tailgate trim
- Parcel shelves
- Trunk floor carpets
- Trunk floor trim
- Floor mats
- Back seat trim

#### Interior floor

- Inner dashes
- Needlepunch carpets
- Tufted carpets
- Floor insulators
- Inner wheelhouse insulators
- Inner trunk floor insulators
- Washable surface flooring

\* Components specifically for vehicles with combustion drive

# The Impact Protection Plate and Flame Shield

### Impact protection plate:

- High impact resistance
- No permanent deformation
- No warpage

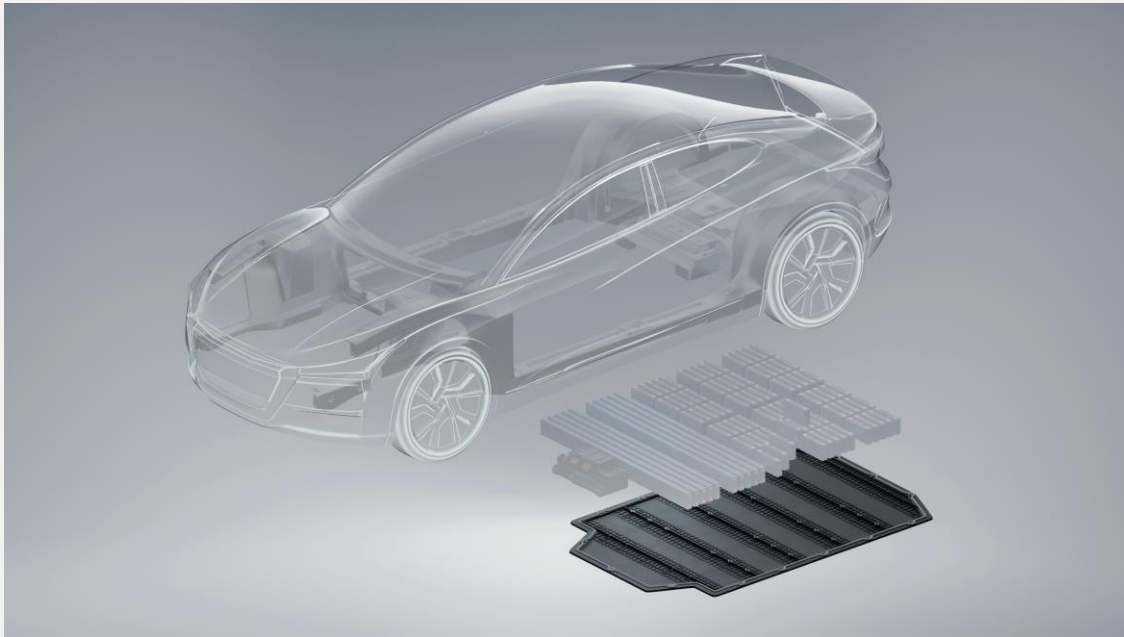

### Flame shield:

- >1400°C local temperature
- Resist to hot particle abrasion
- Ensure 5 minutes escape law

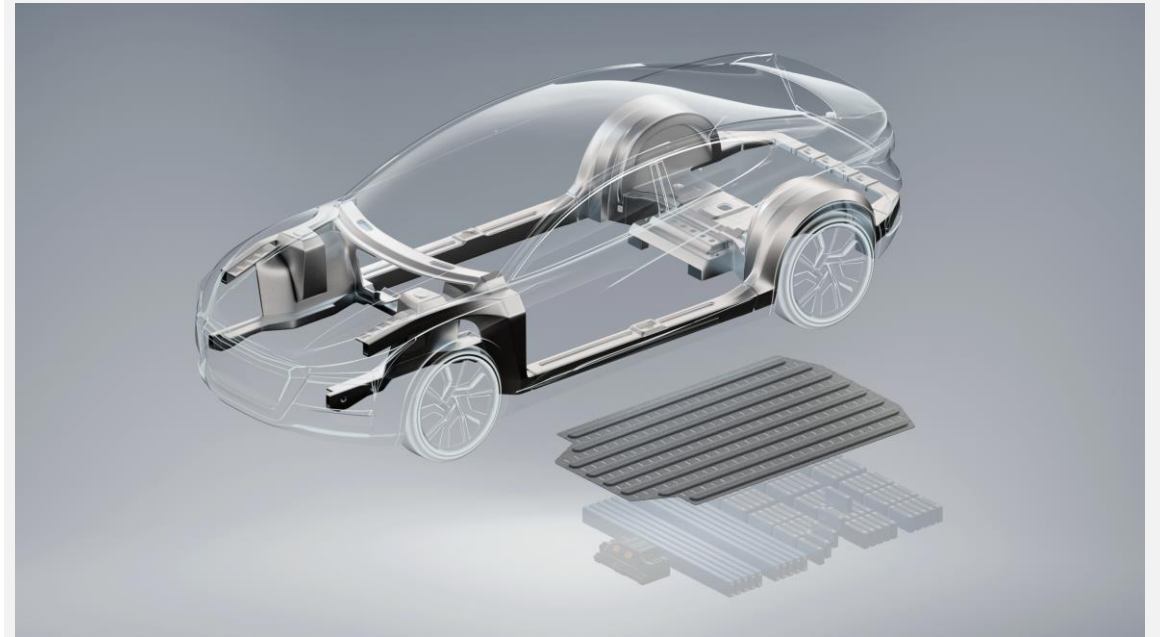

# Leading in Acoustic and Thermal Management

## Our Products for Commercial Vehicles

### Exterior

#### Engine bay

- E-motor and accessory encapsulations
- Engine and gearbox encapsulations\*
- Noise shields

#### Underbody

- Under engine shields
- Heatshields\*

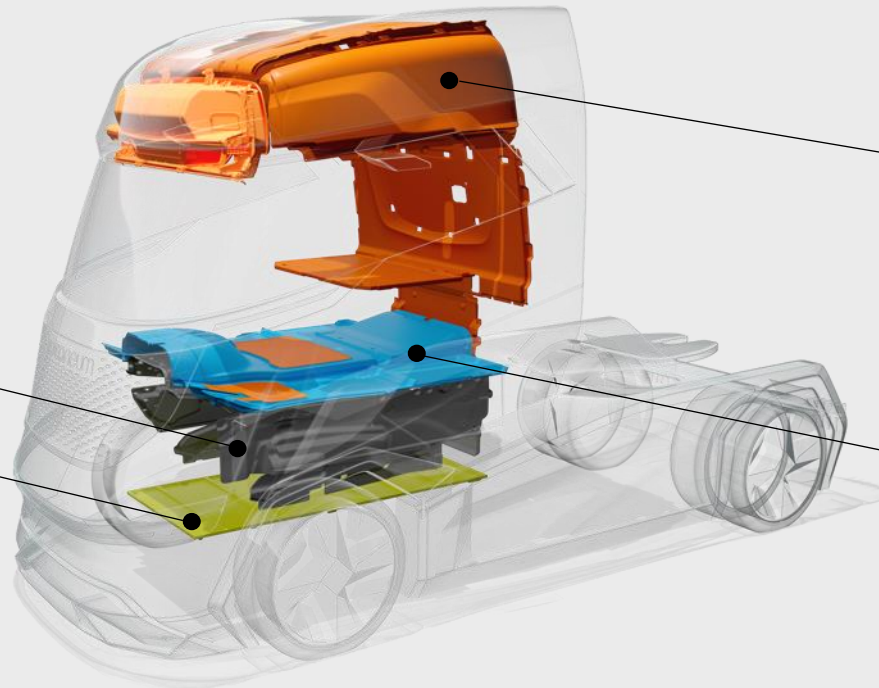

### Interior

#### Interior trim

- Headliners
- Side and rear panels
- (Heated) Floor mats
- Upper storage
- Bunk bed support

#### Interior floor

- Washable surface flooring
- Carpet systems
- Dampers

\* Components specifically for vehicles with combustion drive

# Contact

---



# Contact Persons

---

## Investors and financial analysts

Bernhard Weber  
Head Financial Services & IR

T +41 52 244 82 07

[investor@autoneum.com](mailto:investor@autoneum.com)

## Media

Ulrike Reich  
Head Corporate Communications

T +41 52 244 83 88

[media.inquiry@autoneum.com](mailto:media.inquiry@autoneum.com)

## Contact address

Autoneum Holding Ltd  
Schlosstalstrasse 43 / P.O. Box  
CH-8406 Winterthur

[www.autoneum.com](http://www.autoneum.com)

## Important dates

Publication of Revenue Financial Year 2025	January 23, 2026
Media Conference Financial Year 2025	March 12, 2026
Annual General Meeting 2026	April 28, 2026
Half-Year Results 2026	July 29, 2026

## SIX Swiss Exchange stock listing:

Ticker symbol	AUTN
Securities number	12748036
ISIN	CH0127480363

# Disclaimer

---

Autoneum is making great efforts to include accurate and up-to-date information in this document, however, we make no representations or warranties, expressed or implied, as to the accuracy or completeness of the information provided in this document and we disclaim any liability whatsoever for the use of it. Due to rounding, numbers presented throughout this document may not add up precisely to the totals provided. All ratios and variances are calculated using the underlying amount rather than the presented rounded amount.

The information provided in this document is neither intended nor may be construed as an offer or solicitation for the purchase or disposal, trading or any transaction in any Autoneum securities. Investors must not rely on this information for investment decisions.

All statements in this report which do not reflect historical facts are statements related to the future which offer no guarantee with regard to future performance; they are subject to risks and uncertainties including, but not limited to future global economic conditions, exchange rates, legal provisions, market conditions, activities by competitors and other factors outside Autoneum's control. Autoneum assumes no obligation to update any forward-looking statements or to conform them to future events or developments. The vehicle production figures for 2025 and forward looking are based on the latest estimates of S&P Global Mobility Light Vehicle Production Market Forecast.

autoneum

Autoneum. Mastering sound and heat.

